

Should it be desired to determine experimentally all of the factors (*i. e.*, a and a') of the above equation (IV), the following method may be employed: The apparatus is first filled with dry air. After adjusting the mercury drop, the volume of the contained dry air, the temperature of the bath (t) and the barometric pressure (p) are read. A small measured quantity of water is then run in and the new volume (v) is read. From the data obtained, the aqueous pressure (a) is calculated. After v , p' and t' have been determined by the method described above, the water of the pipette (P) is replaced by concentrated sulphuric acid and a measured quantity of the acid is run in. After the internal pressure (p') is restored by blowing at M, the volume of contained dry air is read and the original aqueous vapor pressure (a') at p' and t' is calculated.

SEATTLE, WASHINGTON.

AN IMPROVED HYGROMETER FOR DETERMINING THE MINIMUM TEMPERATURE OF GAS IN DISTRIBUTION MAINS.

BY C. C. TUTWILER.

Received January 17, 1908.

In the distribution of illuminating gas, it has been found by repeated experiments that the gas will leave the works storage holder saturated with water vapor and also with the vapors of unfixed hydrocarbons, which latter contribute largely to the photogenic value of the gas. This condition of saturation is due to the fact that the gas reaches a temperature in the storage holder which is lower than any temperature to which it has been previously subjected up to this point, and it is therefore saturated with water and hydrocarbon vapors at the temperature of the holder. It has also been found that when the gas enters the relatively colder distribution mains some of these vapors will be dropped, the amount remaining saturating the gas at the lower temperature.

These vapors are unavoidably present. They are not vapors of the oil used in making the gas but are high temperature products of the closed ring series of hydrocarbons formed by the heat necessary to break up the oil into permanent gas. The manner in which these hydrocarbons are dropped out of the gas and again reabsorbed and the effect upon the candle power of the gas is an interesting study which need not be discussed at present, as it has only an indirect bearing upon the subject of this paper. It may not be out of place to say, however, that the aim of the gas engineer is to eliminate from the gas as many of the vapors of low tension high boiling hydrocarbons as possible and to retain those whose tension will permit of their being carried to the burner under all conditions of temperature and pressure met with during distribution.

It is evident that if the gas could be delivered to the consumer at a temperature equal to or greater than that obtaining in the storage holder, there would be no loss of light-producing hydrocarbons in the mains, and the candle power of the gas delivered at the burner, would be the same as that shown at the outlet of the storage holder. While this might seem to represent an ideal method of distribution, it is not practicable from an economic standpoint, as the temperature to which the gas is subsequently cooled in the mains during some seasons of the year is far below the outlet temperature of the storage holder and the cost of reducing the gas to the temperature of the mains at these times would more than offset any advantage gained. It has been found that the gas in the distribution system quickly reaches the temperature of the earth surrounding the mains, and where the mains are exposed, it may even be cooled to the surrounding atmospheric temperature. The attendant loss of hydrocarbon vapors and therefore loss in candle power is considerable, depending upon the so-called "permanency" of the gas and the degree of cold to which it has been subjected. Gases which owe a large percentage of their photogenic value to so-called unfixd hydrocarbon vapors will suffer a greater loss in this respect than those that contain a relatively greater amount of fixed hydrocarbons.

When, therefore, it is required to deliver to the consumer a gas of a uniform candle power throughout all seasons of the year, it is necessary to turn into the distribution mains a gas sufficiently high in candle power to take care of subsequent losses in the mains, which losses will vary from day to day.

The problem at once presents itself as how best to determine what this initial candle power should be, since any excess over and above that actually necessary, means financial loss to the gas company on account of extra enrichment or on the other hand may subject it to penalization if it should fall below that required by contract.

Since the loss in candle power is due to reduction in temperature of the gas in the mains, it will appear at once that the first thing to be determined in the above problem is the minimum temperature to which the gas will be cooled after it leaves the holders, and after having found this temperature to raise or lower the candle power of the holder gas to such an extent that when it is cooled down to the minimum temperature it will still have a candle power equal to that which must be furnished to the consumer.

It was found impossible to determine the minimum temperature by means of thermometers placed in the mains, as the gas continually changed in temperature, owing to its passage through more or less exposed portions of the mains, or on account of its being subjected to other conditions tending to change its temperature, such as rate of flow or nature

of the ground through which the main passed. For these reasons the location of the point of minimum temperature by means of thermometers was found to be exceedingly difficult and unreliable and the attempt was abandoned. A method was finally evolved which depended, for its successful operation, upon the following data:

In the course of a series of experiments made in the Philadelphia Gas Works, it was found that if a gas was cooled down in contact with its condensate to a lower temperature than any to which it had been previously subjected and then allowed to warm up in contact with its condensate to within a few degrees of the original temperature, or, to its original temperature out of contact with its condensate, the water which it would then contain as determined by means of calcium chloride, would just saturate it at the minimum temperature to which the gas had been cooled. An explanation of this is found in the fact that if oil and water are simultaneously deposited the oil will form a film upon the surface of the water, preventing its being again picked up when the temperature is raised so long as any oil remains. It appeared that advantage might be taken of this action and the minimum temperature which the gas had reached in the mains up to any given point be ascertained by determining its water dew point. For this purpose, an ordinary wet and dry bulb psychrometer was employed, the instrument being hung in a bell jar sealed in mercury, through which a current of the gas to be tested was continually passing. The dry bulb thermometer indicates the true temperature of the gas, while the wet bulb thermometer registers the temperature of evaporation, which is usually several degrees below the temperature of the gas. In saturated gaseous atmospheres, the thermometers will read alike and difference will be recorded in proportion to the dryness of the gas. The dew point may be obtained by means of these observations from Glaisher's table by multiplying the difference between the reading of the two thermometers by the factor opposite the dry-bulb reading and subtracting the product from the dry-bulb reading.

This instrument was given a thorough trial and though it furnished some very valuable data, its lack of portability and the knowledge that under the best conditions its indications were known to be only approximately near the truth, caused us to continue our efforts to devise a more satisfactory apparatus.

It was suggested at this time by Mr. Chas. O. Bond, chief photometrician of The United Gas Improvement Company, that the instrument devised by Regnault¹ known as the condenser hygrometer might be adapted to our needs.

The essential parts of this instrument comprise a thin-walled glass

¹ Ann. chim. phys. [3], 15, 129.

vessel quite similar in size and shape to an ordinary 15 cc. test tube, provided with a delicate thermometer and having means for passing air through a small amount of ether contained in the tube. Upon exposing the tube to an atmosphere containing water vapor and reducing the temperature of the tube by volatilizing the ether, moisture will finally be deposited on its outer wall. When this occurs the temperature is read on the thermometer, which reading is the temperature at which the atmosphere would be just saturated with the moisture contained therein, or in other words, its "dew point." The apparatus as designed by Regnault was intended to be used for the determination of the dew point of the atmosphere only, but its principles were successfully utilized in an apparatus which was found to be applicable to the determination of the dew point of any gas. This was accomplished by providing means for surrounding the vaporizing tube with the gas to be tested by the use of an outside jacket through which the gas was made to flow and providing scrubbers for the removal of hydrocarbon and water vapors, the use of which will be explained later on. In the first apparatus designed, air was forced through the ether by means of a rubber hand-pump, and it was found that at times when the dew point was very low, moisture would be deposited in the tube from the air and so cloud the ether that the deposit of dew on the outside of the tube could be seen only with great difficulty. This trouble was finally overcome by using a current of the gas being tested to volatilize the ether, and besides correcting the trouble, the cumbersome hand-pump was thus done away with. This and other improvements tending to compactness, resulted in the improved apparatus about to be described.

The construction and operation of the apparatus is as follows: The interior glass vessel (A) known as the condensing tube, the thermometer (T) and the small tube (B) reaching to the bottom of the condensing tube by means of which the ether is volatilized are quite similar to the essen-

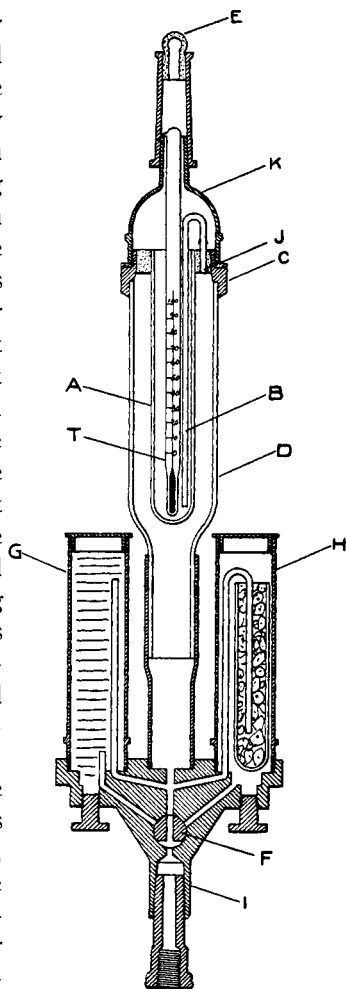

tial parts of Regnault's apparatus, and if this portion of the apparatus is detached from the jacket by unscrewing the collar (C), it may be used in the same way as the Regnault apparatus for obtaining the dew point of the atmosphere. In order, however, to adapt it to our purpose, the glass jacket (D) was provided, through which a stream of the gas to be tested could be made to flow, surrounding the condensing tube in its passage to the burner. The course of the gas from the time it enters the inlet (I) until it issues at the burner (E) on top of the instrument, is as follows:

The cock (F) at the base of the instrument is so constructed that the gas upon reaching the same can be made to flow straightway into the jacket (D) or made to first pass through one or other of the two scrubbing vessels (G and H). In either course it finally passes into the jacket (D) and surrounds the condensing tube (A). It then passes through the hole (J) in the screw cap covering the jacket, and into the tube (B) which runs to the bottom of the condensing tube. The gas after leaving the condenser tube passes into the cap (K) and is finally burned at the burner (E). If a few cubic centimeters of ether or other volatile liquids, such as pentane, are placed in the condensing tube the gas bubbling through will rapidly volatilize it, thereby reducing the temperature of the tube and causing a deposition of dew upon its outer wall as soon as the point of saturation is reached. As soon as this occurs, the thermometer is read and the dew point thus ascertained. It is obvious that the instrument may be placed on any convenient gas bracket and that a few moments will suffice for determining the minimum temperature to which the gas has been cooled, up to that point.

It has been found that the determinations made with the instrument under all ordinary conditions are very reliable. Cases arise, however, when in order to get a correct indication of the minimum temperature, it is necessary to make use of a rubber scrubber to remove some of the hydrocarbon vapors prior to testing the gas and more rarely to use a calcium chloride drying tube to remove a portion of the water vapor. For example, if the gas after having been cooled to its minimum temperature in the mains should pass through a section of main which for some reason was warmer and any liquid hydrocarbon was present in the main at that point, the gas would saturate itself at the higher temperature with hydrocarbon vapor and therefore the instrument would show the dew point of the water vapor which would correctly indicate the minimum temperature. If, however, the gas is first passed through the scrubber (G) which contains finely divided rubber, the hydrocarbon vapors will be removed to such an extent that the amount remaining will not saturate the gas before the dew point corresponding to the water vapor is reached. Such conditions are rarely met with in the dis-

tribution mains. It is well, however, as a precautionary measure to take both hydrocarbon and water vapor dew points and if the hydrocarbon vapor dew point is found to be higher than the water vapor dew point, the latter should be taken as representing the minimum temperature.

Again, it is possible that the gas after having reached its minimum temperature may warm up in contact with water vapor which has been introduced into the gas, as for example in purifiers where steam is admitted for manufacturing reasons. Under such conditions the calcium chloride scrubber (H) must be used and the dew point of the hydrocarbon vapors taken as the minimum temperature.

It is a very simple matter to test the gas in all three ways, *i. e.*, direct, through the rubber scrubber, and through the calcium chloride scrubber, and it has been found advisable in order to get a correct idea of what is taking place or what has taken place in the mains to frequently check the direct readings with readings made after scrubbing the gas.

Such observations also enable the gas engineer to judge whether the gas is being scrubbed by tar or heavy drips deposited in the mains or whether it is picking up hydrocarbons from the mains. If the gas has been cooled to a low temperature as it might be in passing through an exposed main as under a bridge and afterwards warmed up in the ground, as previously stated, we would expect the hydrocarbon vapor dew point to be higher than the water vapor dew point. If the hydrocarbon vapor dew point is lower than the water vapor dew point, it would indicate contact of the gas with a deposit of tar or heavy drip oil.

The practical application of this instrument in gas distribution practice is well defined. Owing to its low specific heat, the gas flowing from the works quickly reaches the temperature of the surrounding earth. The gas engineer knowing by this instrument to what extent the hydrocarbon vapors have been dropped and what the consequent fall in candle power will be, is capable of anticipating the reduction in candle power by raising the candle power of the gas going into the holder accordingly.

LABORATORY OF THE
UNITED GAS IMPROVEMENT COMPANY, PHILADELPHIA,
December 18, 1907.

TECHNICAL METHOD FOR THE DETERMINATION OF LEAD IN ORES, ETC.

By A. H. Low.

Received January 28, 1908.

The following scheme is the result of many attempts on my part to improve the methods wherein lead is separated as oxalate and subsequently titrated with permanganate. I have used the method as described below for several months and have found it more satisfactory